

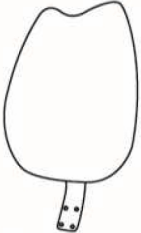

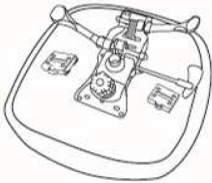



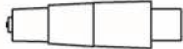

SEAT SLIDER ASSEMBLY INSTRUCTIONS

(1)*1  Back Cushion	(2)*1  Seat Cushion W/Mechanism	(3)*1 (L)*1 (R)  Left-Arm Right-Arm
(4)*5  Caster	(5)*1  Gas Lift W/ Cover	(6)*1  Nylon Base
(7)*1  Seat Slider		
(A)*2  M8 ARM BRACKET SCREW	(B)*3  5/16" * 1" L-BAR SCREW	
(C)*4  1/4" * 1/2" IN SEAT SLIDER	(D)*4  1/4" * 1" ATTACHED TO MECHANISM	

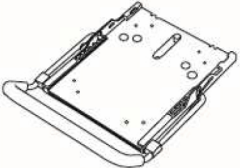
1

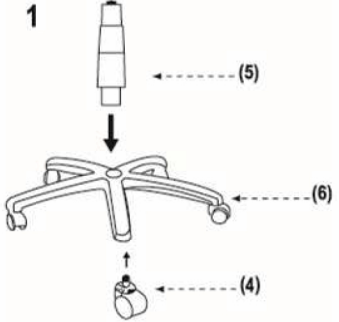

remove 4 type D screws from mechanism and remove mechanism

2

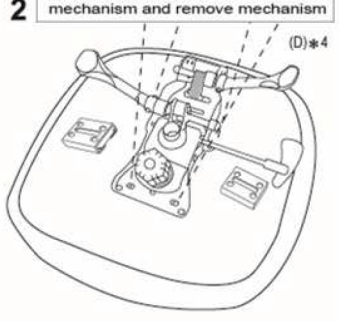

place seat slider over holes and screws in near with 2 type D screws

3

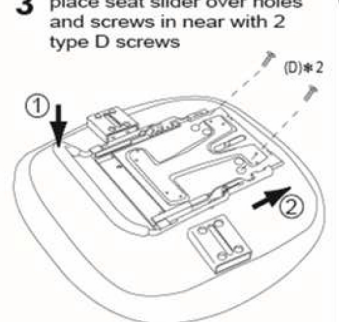

slide back & screw in front with 2 type D screws

4

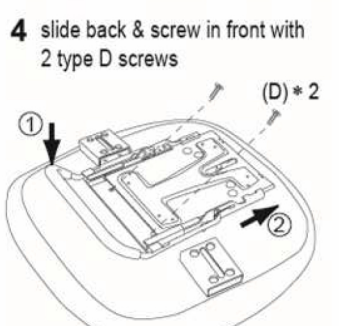

place mechanism over slider & screw in with 4 type C screws

5

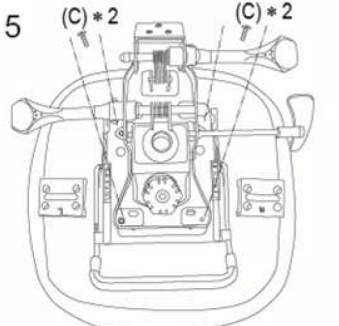

attach back and screw in with 3 type B screws

6

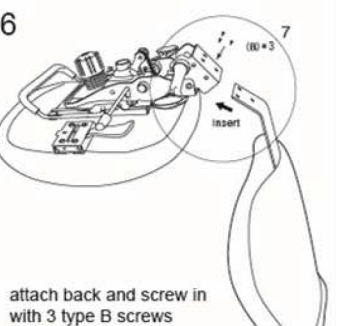

attach arms & screw in with type A screws

7

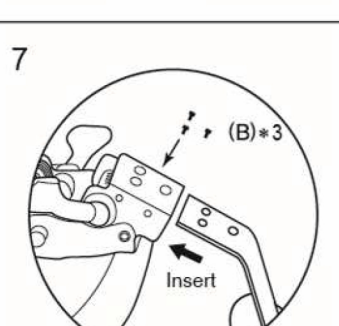

attach arms & screw in with type A screws

8

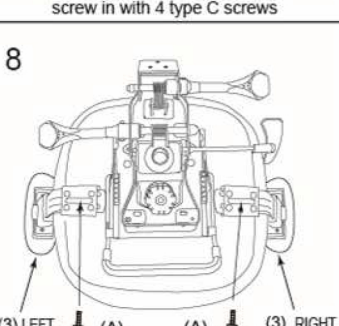

attach arms & screw in with type A screws

9

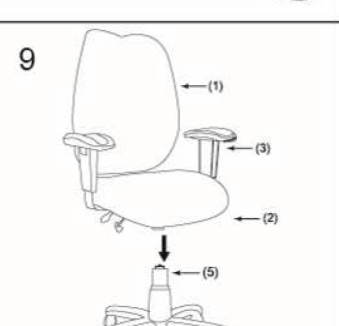

attach arms & screw in with type A screws

Insert and loosely tighten all screws. When assembly is completed, fully tighten all screws before using. This chair is only intended for sitting. Any other use will void the warranty.